

No. 305

Date 10/19/01

*Another addition to the expanding line of Webb products.*

## NEW PRODUCT BULLETIN

### Part Number: **4343 "PLATINUM SERIES" ALUMINUM HUB**

**DESCRIPTION:**

10 Stud Hub - 11.25" (285.75mm) Bolt Circle  
 Uses Outboard Drum - Serrated Stud

WEIGHT: 20 lbs. Hub Only

32.6 lbs. Hub, Cups and Studs

**WEBB AXLE GROUP NO. 4**

OUTER BEARING CUP HM518410 ←  
 CONE HM518445 ← Cup Code 1  
 INNER BEARING CUP HM518410 ←  
 CONE HM518445 ←

<b>AVAILABLE</b>
<b>NOW</b>

Drawing Reference	Item	Dimension
B	Overall Length	8.07
C	Outer Hub Cap Face to Inner Cup Seat	5.95
D	Distance Between Cups	4.50
E	Inner Cup to Mounting Face	
	Cast Drum (0.50 Back Plate Thickness)	1.92
	Platinum Drum (0.25 Back Plate Thickness)	8.07
F	Bolt Circle Diameter	11.25" (285.75mm)
G	Wheel Stud Qty./Thread Diameter	(10) M22x1.5
H	Hub Cap Hole Pattern	6 Holes 0.31 Dia. 6.75 Dia. Bolt Circle

<b>APPLICATION INFORMATION</b>
<b>TRAILER AXLE</b>

**WEBB AXLE GROUP 4**

Dana Spicer.....P-22  
 Eaton.....225P, 230P  
 Fruehauf.....PROPAR  
 Hendrickson.....HP  
 Ingersoll.....A24H, A24S, F24  
 Meritor.....TP

**I. ABS RING**

Part Number: 51554  
 Pitch Diameter: 6.77  
 Cup Seat to Face Dimension: 2.20

**BRAKE DRUM INFORMATION**

J			Estimated Drum Weight	Special Information	K		L	M	N
Brake Drum Order Code					Brake Size (1) Dia. (2) Width		Drum Overall Depth	Drum Pilot Dia.	Cup to End of Drum
Part No.	Standard	Balanced							
61577	UP	RP	107 lbs.		15.00	7.00	10.59	8.78	8.67
66864	UQ	RK	113 lbs.		16.50	7.00	10.62	8.78	8.70
60864	-	ZQ	90 lbs.	Platinum Drum	16.50	7.00	10.37	8.78	8.70
66800	MU	LU	126 lbs.	8" Brake on 7" Centerline	16.50	8.00	11.10	8.78	9.12
66854	JA	KA	128 lbs.	8.62 Brake on 7" Centerline	16.50	8.62	11.46	8.78	9.48

**WEBB WHEEL PRODUCTS, INC.**  
 2310 Industrial Drive, S.W.  
 Cullman, Alabama 35055  
 (256) 739-6660 FAX (256) 739-6246

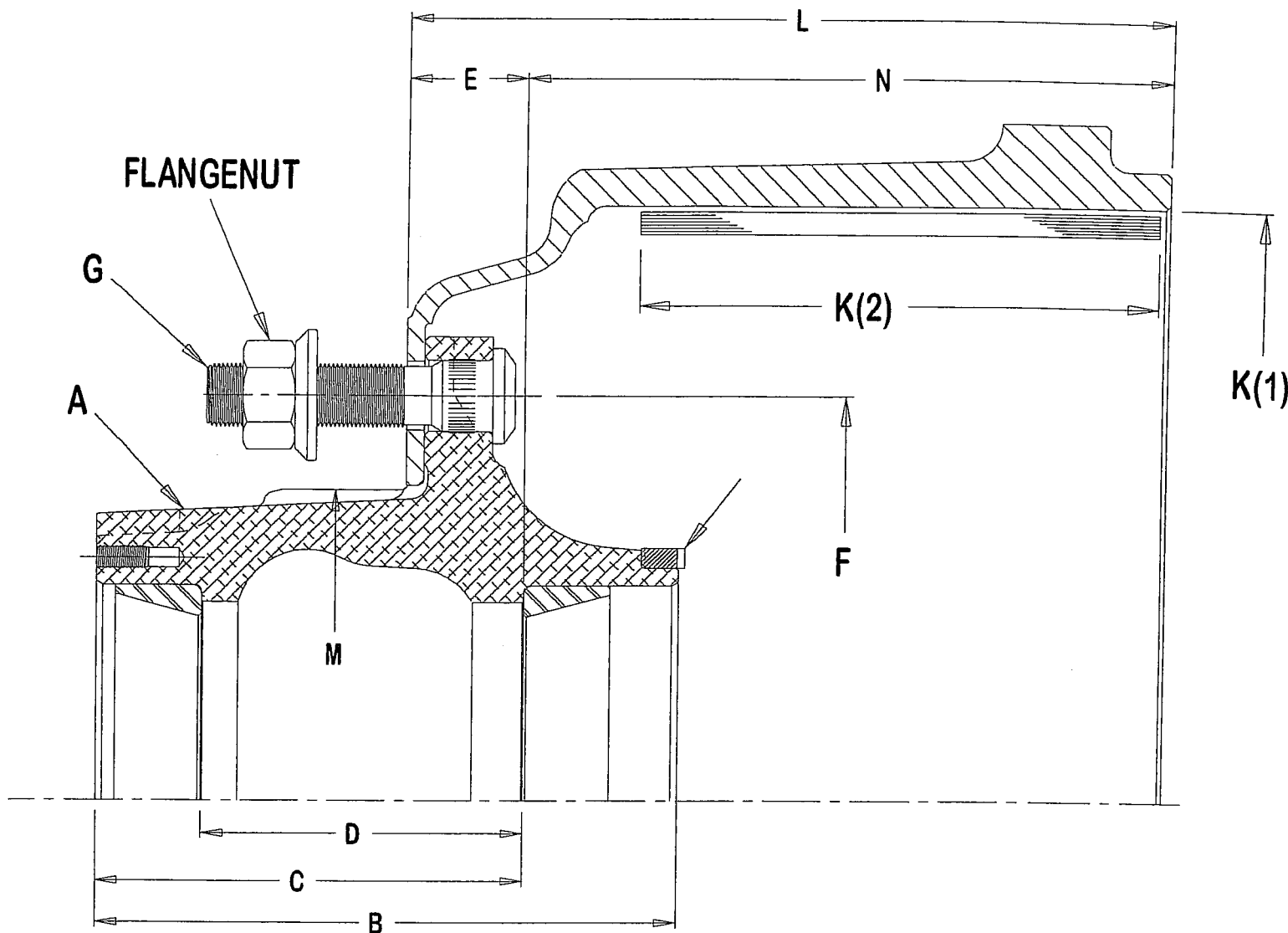

Assembly Drawing

List of Components

Item	Part No.	Description	Qty.
1	4343	Hub, 10 Stud, Outboard	1
2	HM518410	Bearing Cups	2
3	See Chart	Serrated Stud M22 x 1.5	10
4	179933	Flange Nut M22 x 1.5	10
5	60864	Platinum Brake Drum 16.5 x 7	1

Stud Application Chart

Wheel ordering assemblies specify stud desired based on disc wheel and drum combination to be used.			
Disc Wheel	Drum Type	Specify Stud	Stud Standout
Single Steel	Cast	101164	2.08
	Platinum	101164	2.33
Single Alum	Cast	101162	2.53
	Platinum	101164	2.33
Dual Steel	Cast	101162	2.53
	Platinum	101164	2.33
Dual Alum	Cast	101160	3.44
	Platinum	101160	3.69
Dual - 1 Steel/1Alum	Cast	101160	3.44
	Platinum	101162	2.78